



FILTAWORX[®]

Automatic Self-Cleaning Water Filters

FW100EX – FW350

100 - 350mm (4" - 14")



FILTAWORX[®] range of fully automatic self cleaning filters have been designed and built in Australia by an experienced team of engineers using the latest 3D CAD software. FILTAWORX[®] filters are one of the most technically innovative self-cleaning filters available , combining proven high performance, reliability and economy in a compact robust design. Features include:

- ▲ Stainless steel filter body as standard.
- ▲ All parts are made of corrosion resistant materials.
- ▲ Fully automatic back flush operation.
- ▲ Available with hydraulic or electric controls.
- ▲ Large filtration area.
- ▲ Wide range of fine screen sizes, 50 to 800 microns.
- ▲ Standard sizes from DN50 to DN350 (2" – 14").
- ▲ Pressure rating of PN10 as standard.
- ▲ Simple and quick installation.
- ▲ Full support and after sales service.
- ▲ Designed built and tested in Australia.

Advantages of FILTAWORX® Automatic Filters

Stainless Steel body for corrosion resistance in most environments.

Cleaning Mechanism:

The key feature to FILTAWORX® performance and reliability is the use of the escaping backflush water to rotate the internal cleaning mechanism inside the filter vessel. No external motor, mechanism or power is required, reducing the number of moving/wearing parts to a minimum.

Automatic Operation of the self cleaning backflush cycle is achieved when a pre-set pressure drop (40 – 50 kPa) across the filter is reached. 100% cleaning as every spot on the fine screen surface is cleaned with a high velocity, aggressive backflush flow.

No External Power is required (when using the hydraulic controlled filter). All functions are powered by the line pressure only. All controls required come complete with the filter.

Uninterrupted Flow during the backflush cycle.

More Screen Area than any other comparable filter available.

Positive Filtration using a precision 316 stainless steel mesh screen.

Wide Range of Filtration screen sizes available from 50 to 800 micron enabling correct selection for each application. Screens can easily be replaced on-site to alter the degree of filtration if required.

Compact and Simple Installation can be mounted in any position or orientation, with minimal space requirements.

High Reliability due to minimal moving parts, simple design and robust construction make FILTAWORX filters virtually maintenance free.

How FILTAWORX® Works

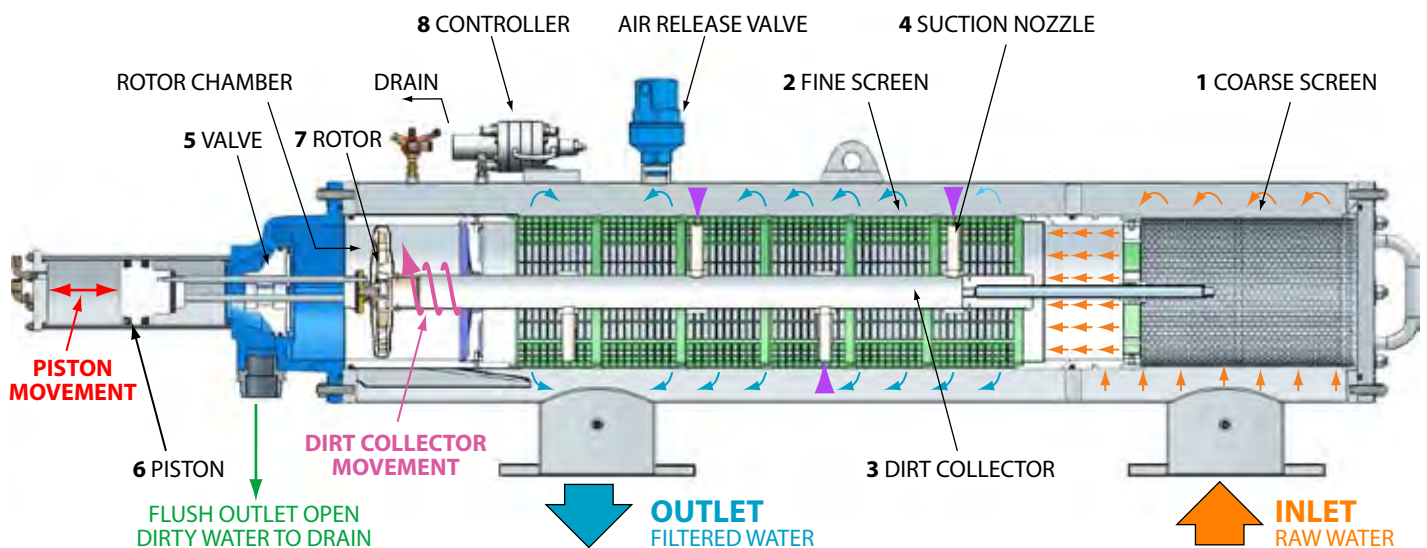

During normal filtering mode the raw water enters the Inlet of the filter, passes through the Coarse Screen (1), (the 7 mm perforations remove large debris that may obstruct the lower mechanism). Water then travels to the inside and through the Fine Screen (2) to the Outlet.

The solids in the water are trapped on the Fine Screen (2), eventually causing a pressure drop (DP) across the filter. At a pressure drop of 40 – 50 kPa the Controller (8) activates the cleaning cycle by opening the Flush Valve (5) to drain (atmosphere).

The interconnection of the Suction Nozzles (4) via the Dirt Collector (3) to the Drain causes a back flushing or 'vacuum clean' effect on the Fine Screen (2) with a high velocity suction jet of water from the clean side of the screen, removing the dirt on the screen as it passes through.

The water escaping via the Rotor (7) causes the Dirt Collector and Suction Nozzle assembly (3 & 4) to rotate. The Piston (6) moves this assembly down the length of the Fine Screen (2) in a spiralling motion, cleaning the entire screen surface area in approximately 15 seconds. The Flushing Valve (5) closes, and the Piston (6) is returned to its original position, ready for the next cycle. Cleaning also occurs on the return stroke.

Typical Application Areas

Irrigation

For the protection of all types of irrigation systems including: drip, micro jet, sprinkler and golf course irrigation systems, from all types of sources including treated effluent.

Cooling Towers and Process Water

Removal of algae, sludge, pipe scale, process impurities and atmospheric contamination, thereby maximising heat transfer efficiency, reducing maintenance, energy and chemical treatment costs of up to 30-50%.

Significant reductions in sludge build-up in basins that sustains and shields legionella bacteria, ensuring a healthier & safer environment.

Surface and Ground Water

For protection of plant and equipment from contamination found in sea, rivers, dams, bores, and other water sources.

Equipment Protection

For pump gland seals, bearings, compressors, valves, etc.

Nozzle Protection

Eliminates blocked nozzles, keeping them clean and open thereby reducing maintenance.

Membrane & UV Protection

Removing problem sized solids that reduce the effectiveness of membranes and UV.

Effluent and Water Re-Use

Allows the re-use/recycling of effluent and other poor quality water within water treatment plants, industrial process systems, pulp and paper mills, mines, irrigation etc.

Town Water Supply

Removes algae, organisms, sand and silt from surface water streams, dams, reservoirs and bores, reducing chemical treatment and maintenance costs.

Technical Specifications

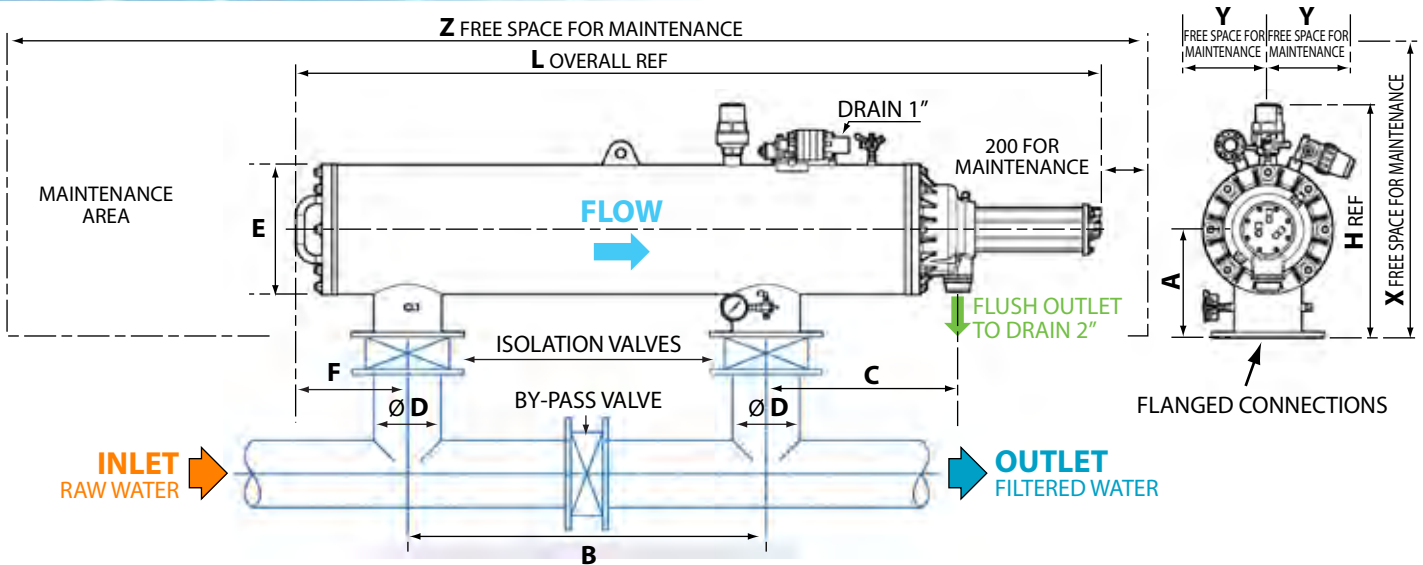

Dimensional Details

Model No	Nominal Size D		Nominal Flow at 2m Head Loss		Filter Area cm ²	Dimensions mm										Weight Kg	
	inch	mm	l/sec	m ² /hr		A	B	C	E	F	H	L	X	Y	Z	Empty	Full
FW 100EX	4	100	28	100	5600	235	900	466	273	229	525	1952	730	360	3650	85	165
FW 150	6	150	50	180	5600	270	900	481	325	279	583	2017	780	360	3720	105	215
FW 150EX	6	150	50	180	8115	270	900	844	325	279	583	2380	780	360	4430	115	265
FW 200	8	200	89	320	8115	270	900	966	325	389	583	2612	780	380	4660	130	320
FW 250	10	250	111	400	8115	270	900	966	325	392	583	2615	780	400	4660	155	345
FW 250EX	10	250	111	400	10415	310	1100	966	406	682	665	3105	870	420	5310	235	540
FW 300	12	300	167	600	10415	310	1100	966	406	682	665	3105	870	420	5310	240	550
FW 350	14	350	250	900	12170	310	1270	966	406	512	665	3105	870	450	5310	285	595

Screen sizes available: 50, 80, 100, 120, 150, 200, 400, 800 micron

Flanges available: Table "D" or "E"; ANSI 150 and ISO/DIN

Standard Materials of Construction: 304 Grade St/St Body & other parts, 316 St/St Mesh Fine Screens, Brass, Glass reinforced Nylon, NBR & EPDM Seals 316 St/St Body available on request

Max Working Pressure: 10 bar (150psi)

Min. Line Pressure required during

Flush Cycle: 2 bar (30psi)

Approx Flush Time: 15 - 17 sec, Vol 150 Litres

Max. Working Temp: 65°C

Selecting the Right Filter

Selecting the right FILTAWORX® filter for your particular application is crucial in achieving the best result. We recommend it be done in consultation with your FILTAWORX® dealer or Triangle Waterquip, who have extensive experience and know-how to assist you.

The following information will help you and us make the correct selection.

1. The application and equipment you are protecting.
2. Maximum and minimum flow rate that the filter will need to handle.
3. System operating pressure, and pump details/curve if available.
4. Level of filtration/screen size required.
5. Dirt loading (Total Suspended Solids - TSS) of the water, if known.
6. Type of solids that are present, i.e. sand, algae, paper fibre, etc.
7. Filter control logic other than standard that may be required.
8. Water temperature and any chemical/corrosiveness content if known.



PRESSURE LOSSES FOR VARIOUS FLOW CAPACITIES

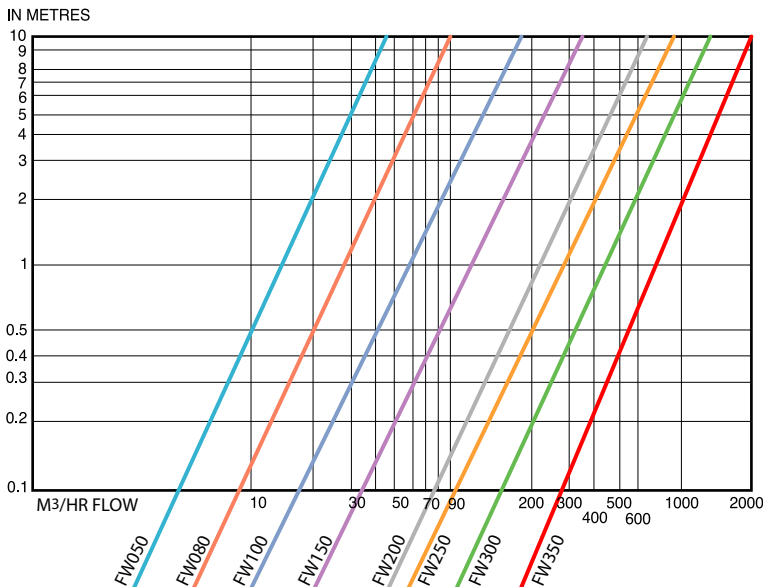

TRIANGLE WATERQUIP PTY. LTD.

ABN 31 007 023 323
 17 Hinkler Road,
 Mordialloc, Vic. 3195, Australia
 Phone: (03) 9580 2122
 Fax: (03) 9580 3131
 Email: triangle@trianglewaterquip.com.au
www.trianglewaterquip.com.au
AUSTRALIAN OWNED AND OPERATED

AVAILABLE FROM



FILTAWORX[®]

Automatic Self-Cleaning Water Filters

FW050 - FW100

50 - 100mm (2" - 4")

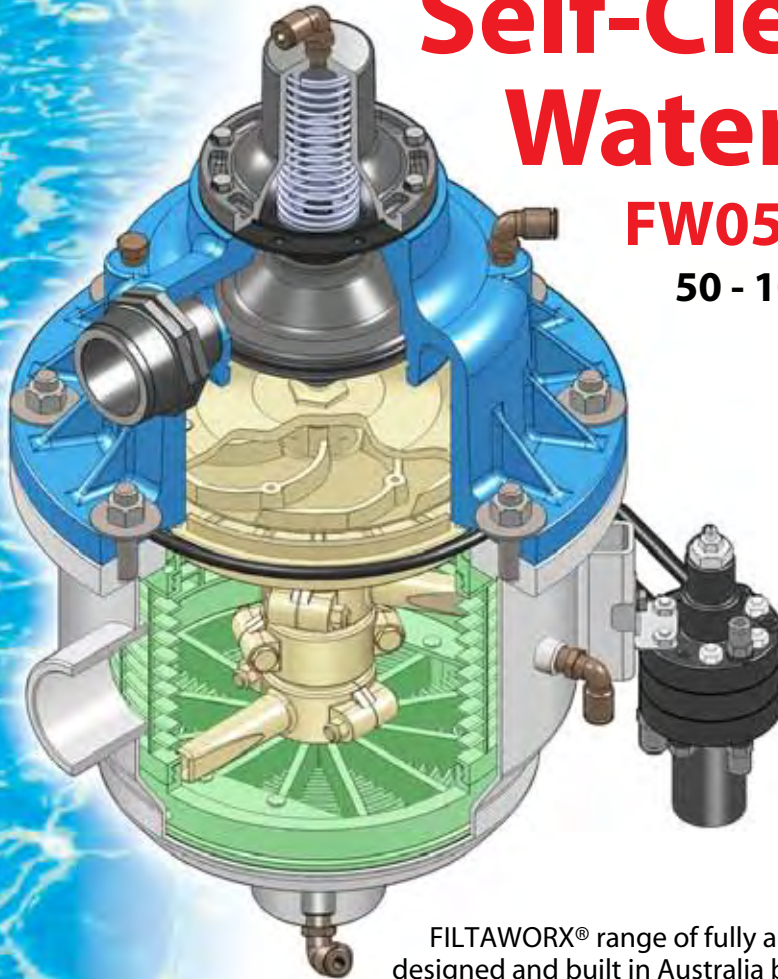

FILTAWORX[®] range of fully automatic self cleaning filters have been designed and built in Australia by an experienced team of engineers using the latest 3D CAD software. FILTAWORX[®] filters are one of the most technically innovative self-cleaning filters available, combining proven high performance, reliability and economy in a compact robust design.

Features include:

- ▲ Stainless steel filter body as standard.
- ▲ All parts are made of corrosion resistant materials.
- ▲ Fully automatic back flush operation.
- ▲ Available with hydraulic or electric controls.
- ▲ Large filtration area.
- ▲ Wide range of fine screen sizes, 50 to 800 microns (250 - 20 mesh).
- ▲ Standard sizes from DN50 to DN350 (2" - 14").
- ▲ Pressure rating of PN10 as standard.
- ▲ Simple and quick installation.
- ▲ Full support and after sales service.
- ▲ Designed, built and tested in Australia.

Advantages of FILTAWORX® Automatic Filters

Stainless Steel body for corrosion resistance in most environments.

Cleaning Mechanism:

The key feature to FILTAWORX® performance and reliability is the use of the escaping backflush water to rotate the internal cleaning mechanism inside the filter vessel. No external motor, mechanism or power is required, reducing the number of moving/wearing parts to a minimum.

Automatic Operation of the self cleaning backflush cycle is achieved when a pre-set pressure drop (40 - 50 kPa) across the filter is reached. 100% cleaning as every spot on the fine screen surface is cleaned with a high velocity, aggressive backflush flow.

No External Power is required (when using the hydraulic controlled filter). All functions are powered by the line pressure only. All controls required come complete with the filter.

Uninterrupted Flow during the backflush cycle.

More Screen Area than any other comparable filter available.

Positive Filtration using a precision 316 stainless steel mesh screen.

Wide Range of Filtration screen sizes available from 50 to 800 micron (250 - 20 mesh) enabling correct selection for each application. Screens can easily be replaced on-site to alter the degree of filtration if required.

Compact and Simple Installation can be mounted in any position or orientation, with minimal space requirements.

High Reliability due to minimal moving parts, simple design and robust construction make FILTAWORX® filters virtually maintenance free.

How FILTAWORX® Works

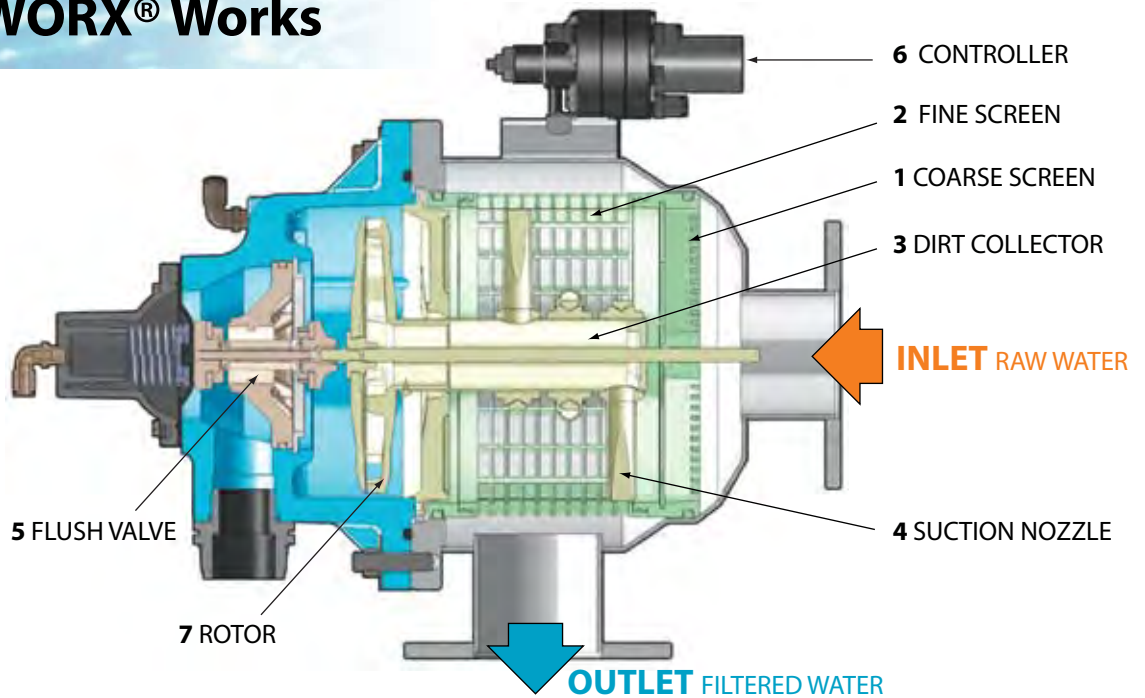

During normal filtering mode the raw water enters the Inlet of the filter, passes through the Coarse Screen (1), (this removes large debris that may obstruct the lower mechanism). Water then travels to the inside and through the Fine Screen (2) to the Outlet.

The solids in the water are trapped on the Fine Screen (2), eventually causing a pressure drop (DP) across the filter. At a pressure drop of 40 - 50 kPa, the Controller (6) activates the cleaning cycle by opening the Flush Valve (5) to drain (atmosphere).

The interconnection of the Suction Nozzles (4) via the Dirt Collector (3) to the Drain causes a back flushing or 'vacuum clean' effect on the Fine Screen (2) with a high

velocity suction jet of water from the clean outlet side of the screen, removing the dirt on the screen as it passes through.

The water escaping via the Rotor (7) causes the Dirt Collector and Suction Nozzle assembly (3 & 4) to rotate. The Flushing Valve (5) allows this assembly to travel along the length of the Fine Screen (2) in a spiralling motion, cleaning the entire screen surface area in approximately 5 seconds. The Flushing Valve (5) closes, and returns the mechanism back to its original position, ready for the next cycle. Cleaning also occurs on the return stroke.

Typical Application Areas

Irrigation

For the protection of all types of irrigation systems including: drip, micro jet, sprinkler and golf course irrigation systems, from all types of sources including treated effluent.

Cooling Towers and Process Water

Removal of algae, sludge, pipe scale, process impurities and atmospheric contamination, thereby maximising heat transfer efficiency, reducing maintenance, energy and chemical treatment costs of up to 30-50%.

Significant reductions in sludge build-up in basins that sustains and shields legionella bacteria, ensuring a healthier & safer environment.

Surface and Ground Water

For protection of plant and equipment from contamination found in sea, rivers, dams, bores, and other water sources.

Equipment Protection

For pump gland seals, bearings, compressors, valves, etc.

Nozzle Protection

Eliminates blocked nozzles, keeping them clean and open thereby reducing maintenance.

Membrane & UV Protection

Removing problem sized solids that reduce the effectiveness of membranes and UV.

Effluent and Water Re-Use

Allows the re-use/recycling of effluent and other poor quality water within water treatment plants, industrial process systems, pulp and paper mills, mines, irrigation etc.

Town Water Supply

Removes algae, organisms, sand and silt from surface water streams, dams, reservoirs and bores, reducing chemical treatment and maintenance costs.

Technical Specifications

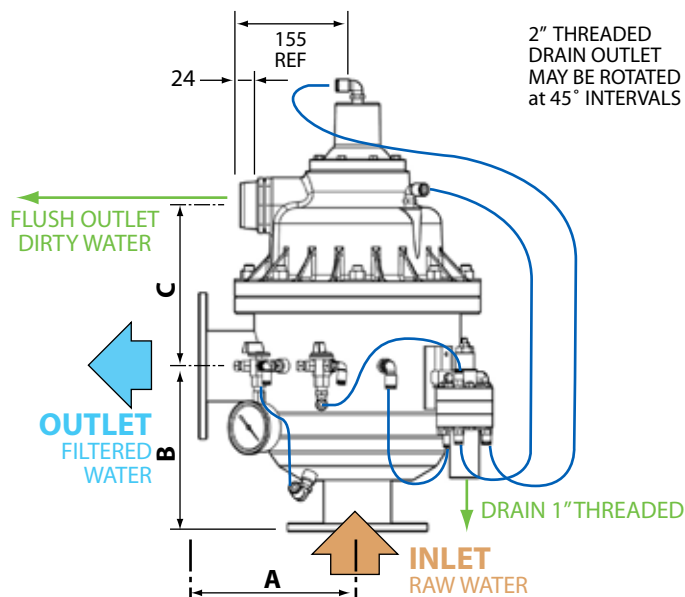
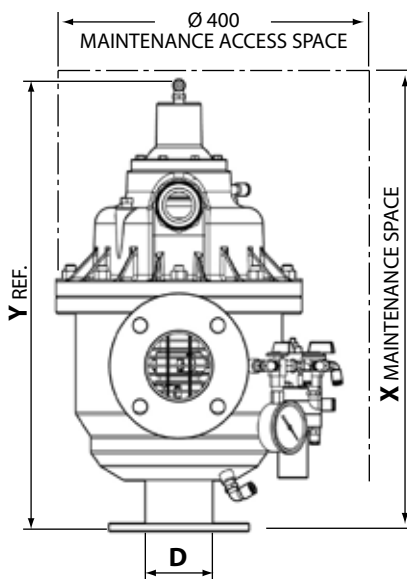

Dimensional Details

Model No	Nominal Size D		Inlet & Outlet Connectors	Nominal Flow at 2m Head Loss		Filter Area cm ²	Dimensions mm					Weight Kg	
	inch	mm		l/sec	m ³ /hr		A	B	C	X	Y	Empty	Full
FW 050	2	50	2" Sockets	7	25	1220	184	198	204	720	560	22	42
FW 050 - F	2	50	2" Flanged	7	25	1220	210	210	204	720	575	23	43
FW 080	3	80	3" Sockets	14	50	1220	194	213	204	720	575	22	42
FW 080 - F	3	80	3" Flanged	14	50	1220	210	210	204	720	575	25	45
FW 080 - EX	3	80	3" Flanged	14	50	1980	210	315	215	900	680	29	55
FW 100	4	100	4" Flanged	22	80	1980	235	315	215	900	690	30	57

Max Working Pressure: 10 bar (150 psi)
 Min. Line Pressure required during Flush Cycle: 2 bar (30 psi)
 Approx Flush Time: 5 - 7 sec, Vol 30 Litres
 Max. Working Temp: 65 °C

Standard Materials of Construction:

304 Grade St/St Body & other parts,
 316 St/St Mesh Fine Screens, Brass,
 Glass reinforced Nylon, NBR & EPDM Seals
 316 St/St Body available on request

Screen sizes available

Micron	50	80	100	120	150	200	400	800
Mesh	250	200	150	120	100	80	40	20

Selecting the Right Filter

Selecting the right FILTAWORX® filter for your particular application is crucial in achieving the best result. We recommend it be done in consultation with your FILTAWORX® dealer or Triangle Waterquip, who have extensive experience and know-how to assist you.

The following information will help you and us make the correct selection.

1. The application and equipment you are protecting.
2. Maximum and minimum flow rate that the filter will need to handle.
3. System operating pressure, and pump details/curve if available.
4. Level of filtration/screen size required.
5. Dirt loading (Total Suspended Solids - TSS) of the water, if known.
6. Type of solids that are present, i.e. sand, algae, paper fibre, etc.
7. Filter control logic other than standard that may be required.
8. Water temperature and any chemical/corrosive content if known.



PRESSURE LOSSES FOR VARIOUS FLOW CAPACITIES

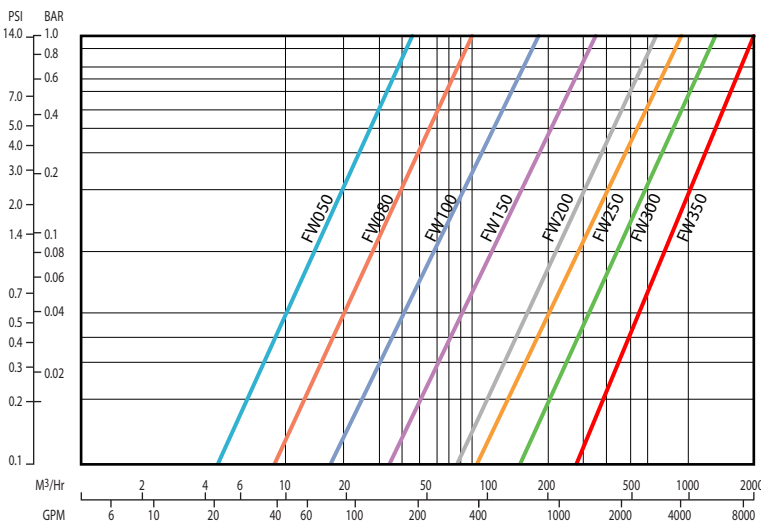

TRIANGLE WATERQUIP PTY. LTD.

ABN 31 007 023 323
 17 Hinkler Road,
 Mordialloc, Vic. 3195, Australia
 Phone: +61 3 9580 2122
 Fax: +61 3 9580 3131
 Email: triangle@trianglewaterquip.com.au
www.trianglewaterquip.com.au
AUSTRALIAN OWNED AND OPERATED

AVAILABLE FROM