

# MULTIDRAIN UV3

## SUBMERSIBLE DRAINAGE PUMP

The MultiDrain UV3 is a versatile drainage pump with stainless steel casing and a vertical discharge, making this an ideal grey water pump for portable applications. The SF model with a vertical float offers the perfect solution for discharging wastewater from a narrow pit from as small as 22cm in diameter.



UV3-SF

UV3-S

### KEY FEATURES

- High quality stainless steel design
- Cooling jacket for motor housing
- Free passage 10 mm
- Vertical discharge branch 1 1/4"
- Moisture sealed cable inlet
- Fluid temperature 35 °C, temporarily 70 °C (10 min.)



Introducing

 **PENTAIR JUNG PUMPEN**

# MULTIDRAIN UV3

## SUBMERSIBLE DRAINAGE PUMP

### MULTIDRAIN UV3 IS A VERSATILE SUBMERSIBLE DRAINAGE PUMP IDEAL FOR PORTABLE AND STATIONARY USE.

The UV3 has an easy-to-activate flushing device that pumps rainwater, domestic grey water and lightly polluted wastewater. Casing made of stainless steel for longer lasting performance. Motor cooling jacket ensures submerged operation without the risk of overheating. When the strainer base is removed, it can suction out residual water down to a level of 5 mm.

The UV3 comes in two variants – UV3-S and UV3-SF. Either one is well-suited for narrow pits and the perfect pump for mobile applications.



#### FEATURES

- Made of high-quality stainless steel for robustness and long-life
- Well-suited for mobile use and ideal for narrow pits
- Thermal motor protection that switches off automatically when a critical temperature is reached
- Maximum operating fluid temperature of up to 35° C, temporarily 70° C (10 min)
- Removable strainer to allow pumping to as low as 5mm
- Cooling jacket on motor to prevent overheating during operation
- Safe ventilation to prevent air lock during stationary operation

#### MULTIDRAIN UV3

Model	Part No.	Cable	Wires	Weight
UV3-S	JP50041	10m H07RN-F	3G1,0	5.5 kg
UV3-SF	JP50042	10m H07RN-F	3G1,0	5.5 kg

#### PERFORMANCE

Delivery head H [m]	1	2	3	4	5	6
Flow rate Q [L/min]	117	107	96	87	67	43

#### MECHANICAL DATA

Pump	Vertical single-stage	Dry run protection	Yes
Free-passage	10mm	Shaft	AISI 304
Bearing	Ball bearings, grease-lubricated	Impeller	Vortex impeller, GFK
Seal on motor side	Rotary shaft seal	Motor housing	AISI 304
Seal on medium side	3-fold rotary shaft seal	Pump housing	AISI 304



13



**PERFORMANCE**

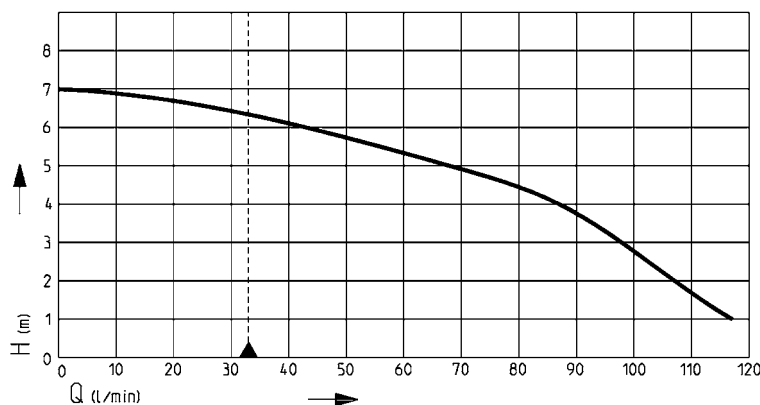

ELECTRICAL DATA	
Pump voltage	230V AC, 50Hz
Motor rating P1	0.34 kW
Motor rating P2	0.23 kW
Current	1.5 A
Type of enclosure	IP 68
Insulation class	F
Winding thermostat	Yes
Motor protection	Integrated
Plug	AS3112, 3 pin

**Multidrain UV3-SF** with close-fitting float:  
Ideal for narrow chambers from Ø 22 cm

**Multidrain UV3-S**  
with built-in level control

**Fluid temperature** -  
35 °C, temporarily 70 °C  
(10 Min.)

**Thermal motor protection** - auto shut-off when a critical motor temperature is reached

**Removable strainer base for low-level pumping suction** -  
5 mm residual water level



**Moisture sealed cable inlet** - protects the motor from water ingress if the cable is damaged

**High quality stainless steel design** for robustness and long-life

**Cooling jacket for motor housing** - prevents the motor from overheating

**Safe ventilation** - prevents the build up of air pockets in stationary operation

**Flushing device** - ensures a clean shaft

## DIMENSIONS

Dimensions and switching points UV3 S (mm)

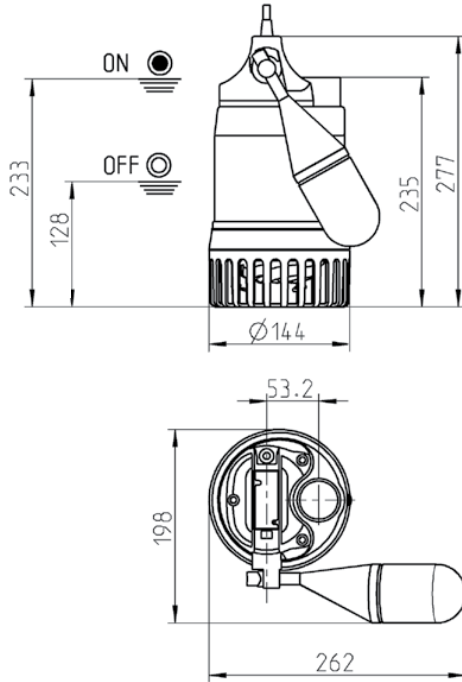

Dimensions and switching points special float UV3 SF (mm)

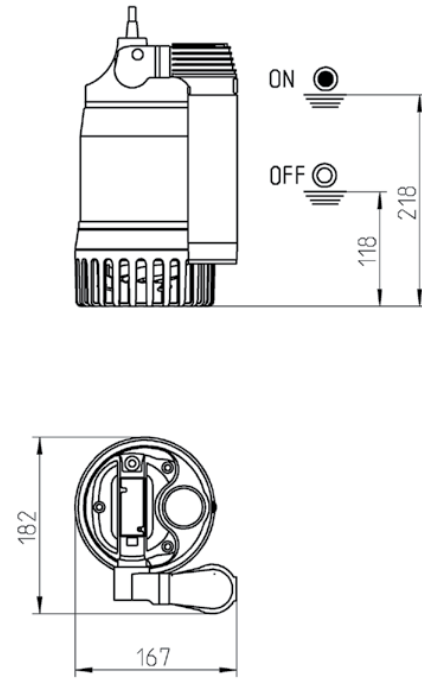

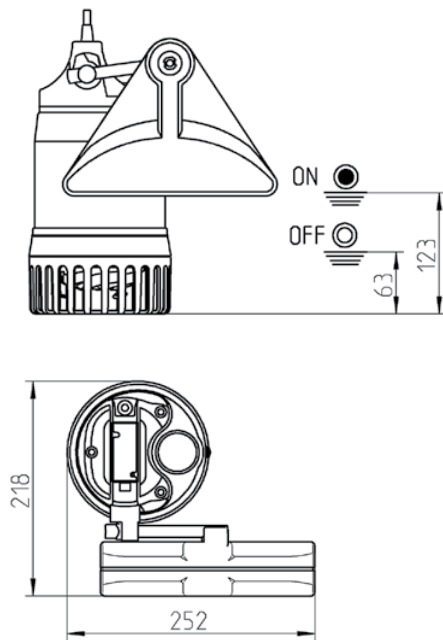

Dimensions and switching points special float UV3 S (mm)

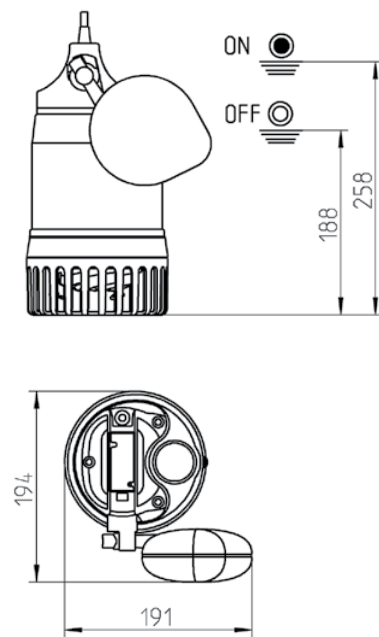

Dimensions and switching points special float UV3 S (mm)



MECHANICAL ACCESSORY			Part No.
	Special float	for lower switching points	JP44795
	Special float	for narrow chambers (min. 30x30 od $\varnothing 30$ cm)	JP40856



1-21 Monash Drive | Dandenong South, VIC 3175 | Australia | 1300 137 344 | [pentair.com.au](http://pentair.com.au)

Information contained here-in remains the property of Pentair under Australian copyright law. Content may not be reproduced or transmitted without our prior written permission.

© 2022 Pentair. All rights reserved. This document is subject to change without notice.